

# OFFICE G26



GARTENSTRASSE ZÜRICH

## BÜRO

**ADRESSE:**  
Gartenstrasse 26, 8002 Zürich

**ETAGE:**  
2. Obergeschoss

**MIETFLÄCHE:**  
ca. 322 m<sup>2</sup>

-  Bürofläche
-  Verkehrsfläche

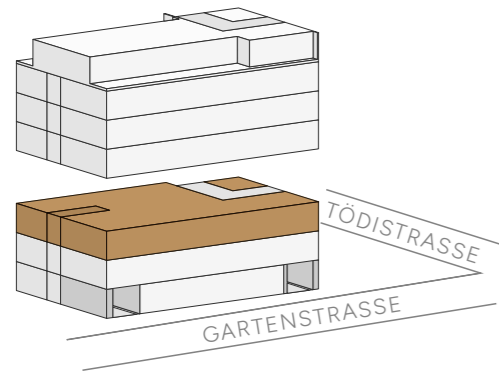

### MASSTAB GRUNDRISS 1:100

(Bei unskaliertem Ausdruck auf DIN A3)



Alle Angaben sind Circaangaben.

INNENHOF

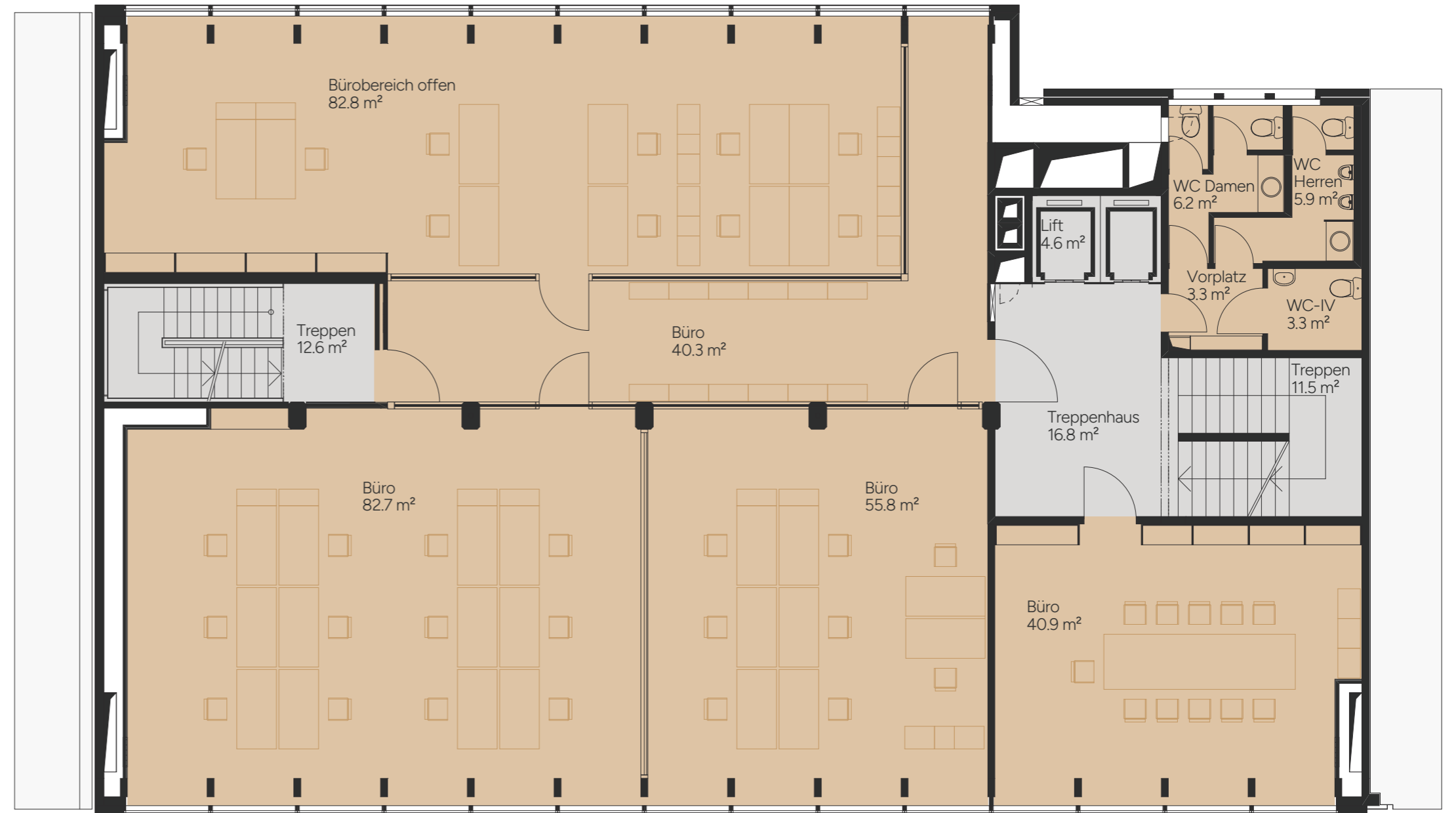

GARTENSTRASSE