

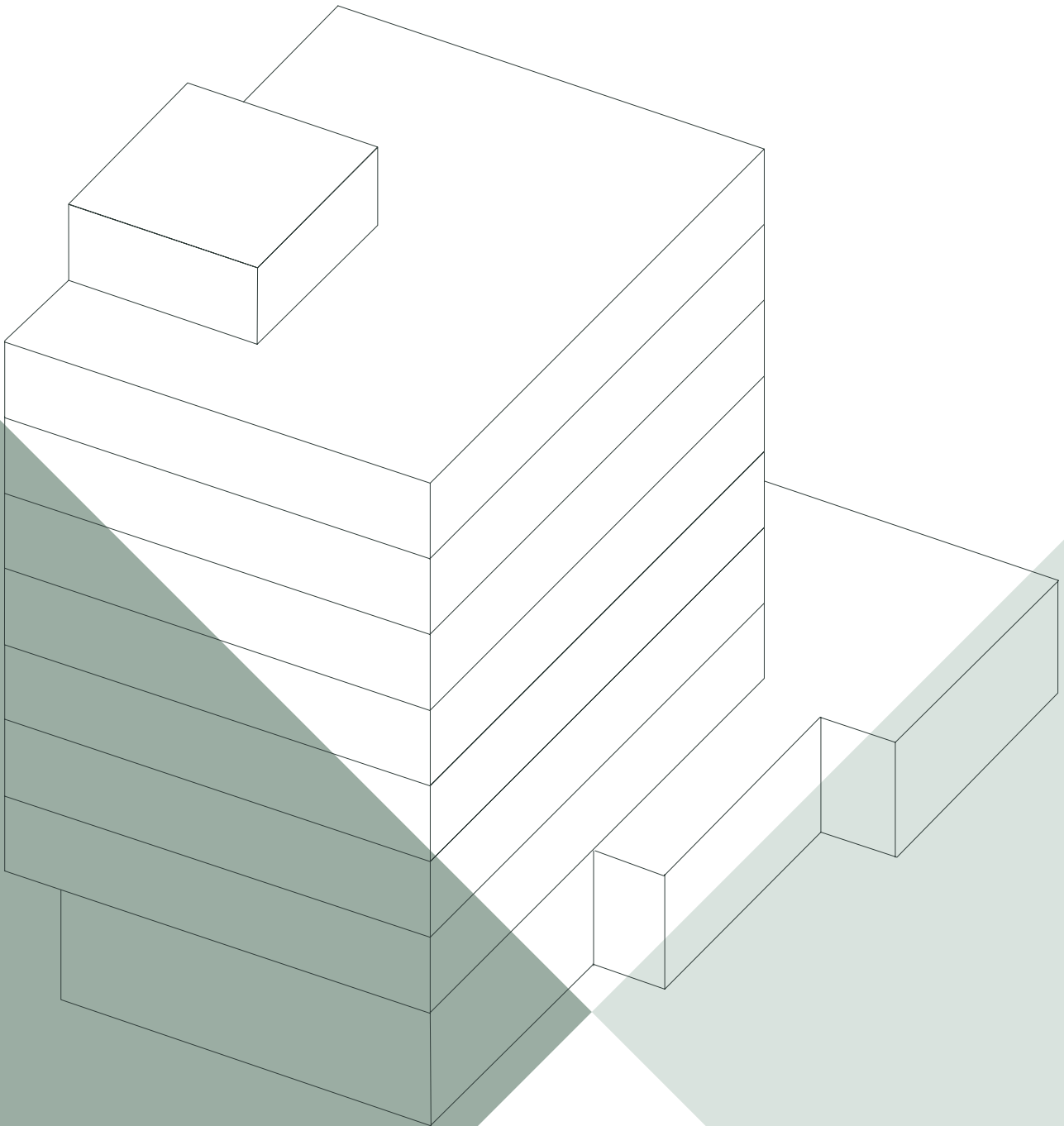

BACHMATT59
ZÜRICH-ALTSTETTEN

GRUNDRISSE
29 MIETWOHNUNGEN
1 BUSINESSFLÄCHE

www.bachmatt59.ch



INHALT

ANNEX & HOCHHAUS

- 4 **o. ERDGESCHOSS**
- 6 **1. OBERGESCHOSS**
- 8 **2. OBERGESCHOSS**
- 10 **3. OBERGESCHOSS**

HOCHHAUS

- 12 **4.-7. OBERGESCHOSS**

0. ERDGESCHOSS ANNEX & HOCHHAUS

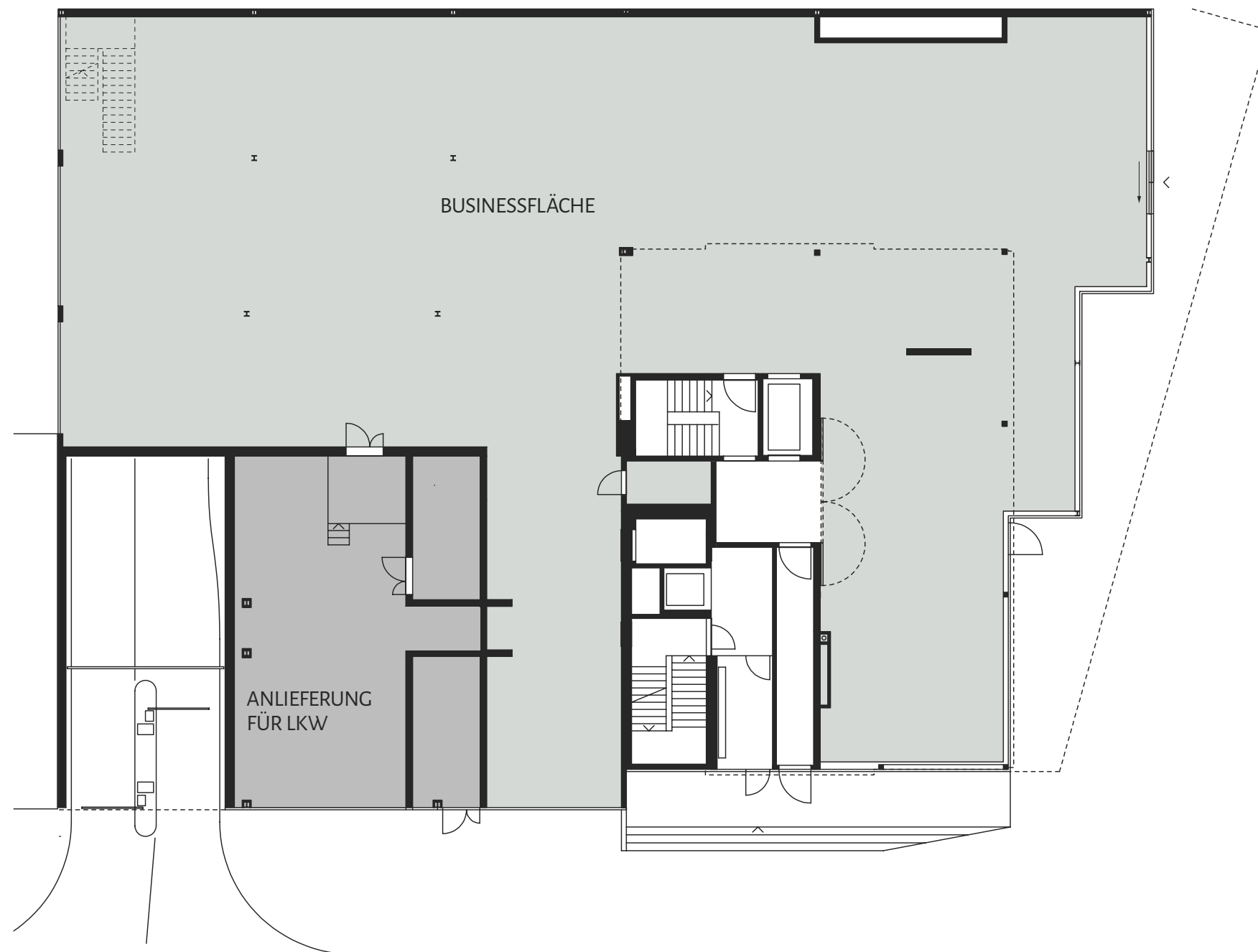
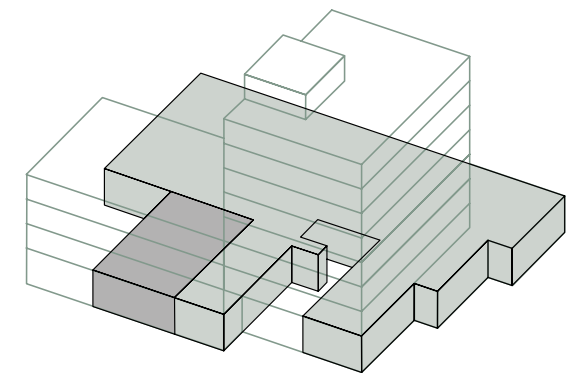

Businessfläche EG ■ ca. 798 m²
 Anlieferung EG ■ ca. 99 m²
 Parkplätze vorhanden

BACHMATTSTRASSE

0 1 2 5 M1:200



1. OBERGESCHOSS ANNEX & HOCHHAUS

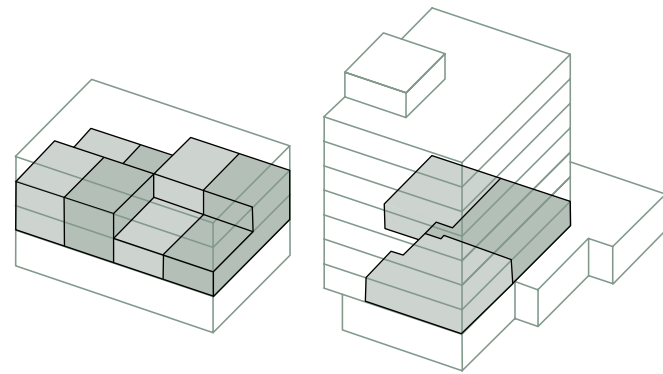

3-Zimmer-Maisonette-Wohnung 206	1./2.OG
Nettowohnfläche	92,0 m ²
Balkon	6,0 m ²

3-Zimmer-Maisonette-Wohnung 209	1./2.OG
Nettowohnfläche	91,0 m ²
Balkon	6,0 m ²

3-Zimmer-Maisonette-Wohnung 205	1./2.OG
Nettowohnfläche	92,0 m ²
Balkon	6,0 m ²

2½-Zimmer-Maisonette-Wohnung 104	1./2.OG
Nettowohnfläche	92,0 m ²
Balkon	6,0 m ²

2½-Zimmer-Wohnung 101	1.OG
Nettowohnfläche	63,1 m ²

1½-Zimmer-Wohnung 103	1.OG
Nettowohnfläche	71,0 m ²
Loggia	6,5 m ²

2½-Zimmer-Wohnung 102	1.OG
Nettowohnfläche	69,0 m ²
Loggia	6,5 m ²

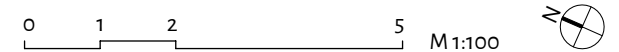

2. OBERGESCHOSS ANNEX & HOCHHAUS

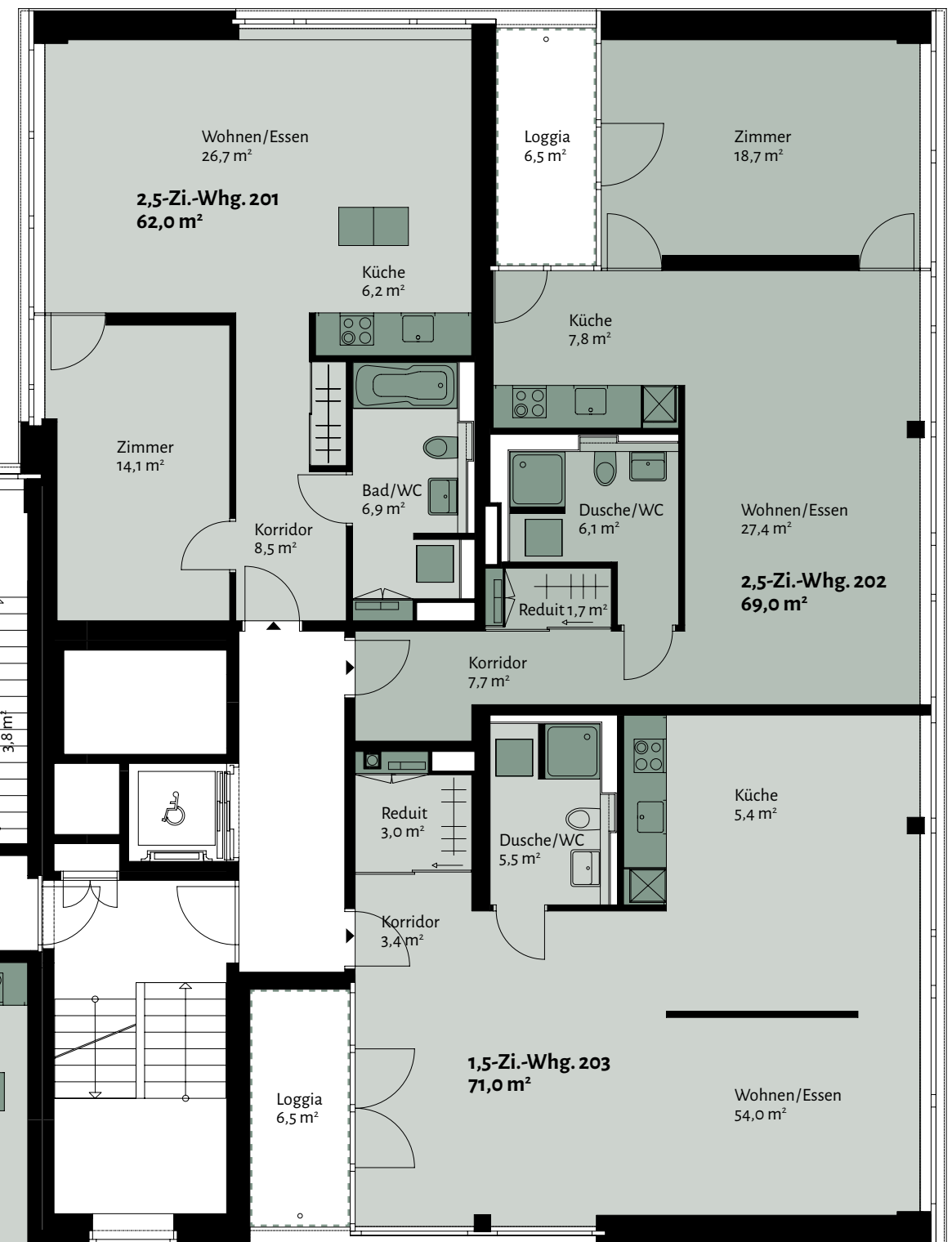
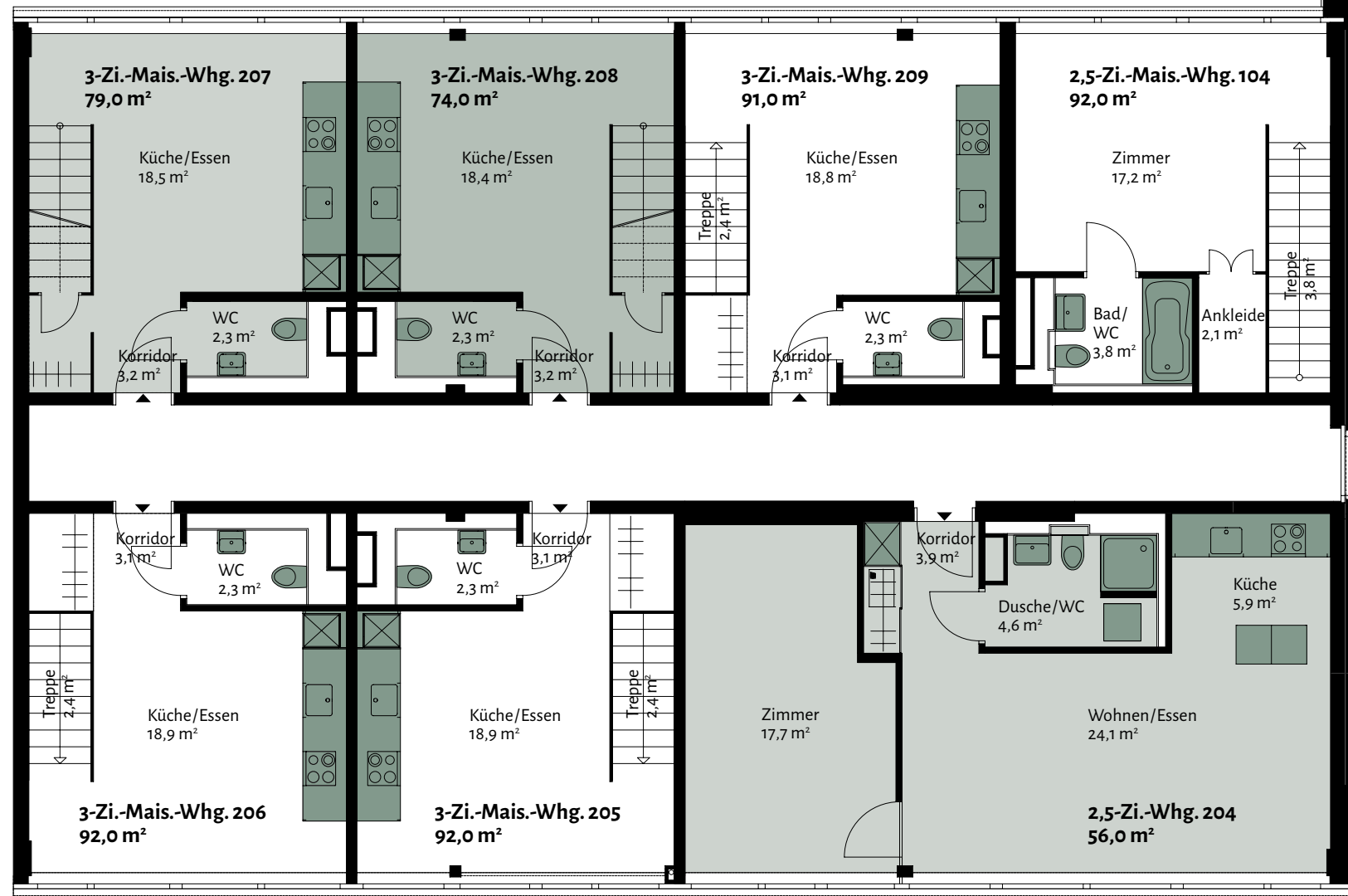
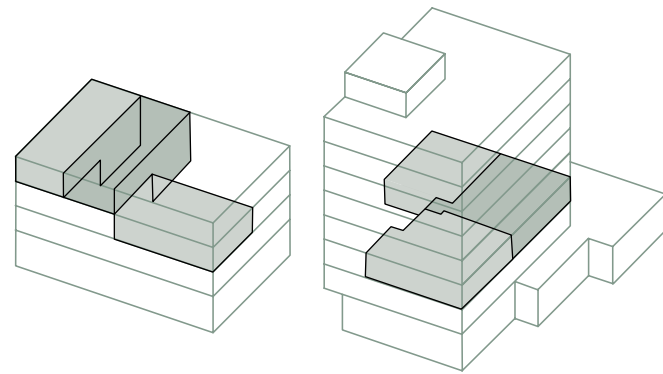

3-Zimmer-Maisonette-Wohnung 207	2./3. OG	2½-Zimmer-Wohnung 204	1./2. OG
Nettowohnfläche	79,0 m ²	Nettowohnfläche	56,0 m ²
Terrasse	10,2 m ²		

3-Zimmer-Maisonette-Wohnung 208	2./3. OG
Nettowohnfläche	74,0 m ²
Terrassen	6,9 m ² /10,6 m ²

2½-Zimmer-Wohnung 201	2. OG	1½-Zimmer-Wohnung 203	2. OG
Nettowohnfläche	63,1 m ²	Nettowohnfläche	71,0 m ²
		Loggia	6,5 m ²

2½-Zimmer-Wohnung 202	2. OG
Nettowohnfläche	69,0 m ²
Loggia	6,5 m ²

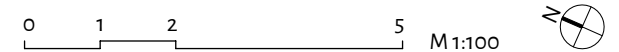

3. OBERGESCHOSS ANNEX & HOCHHAUS

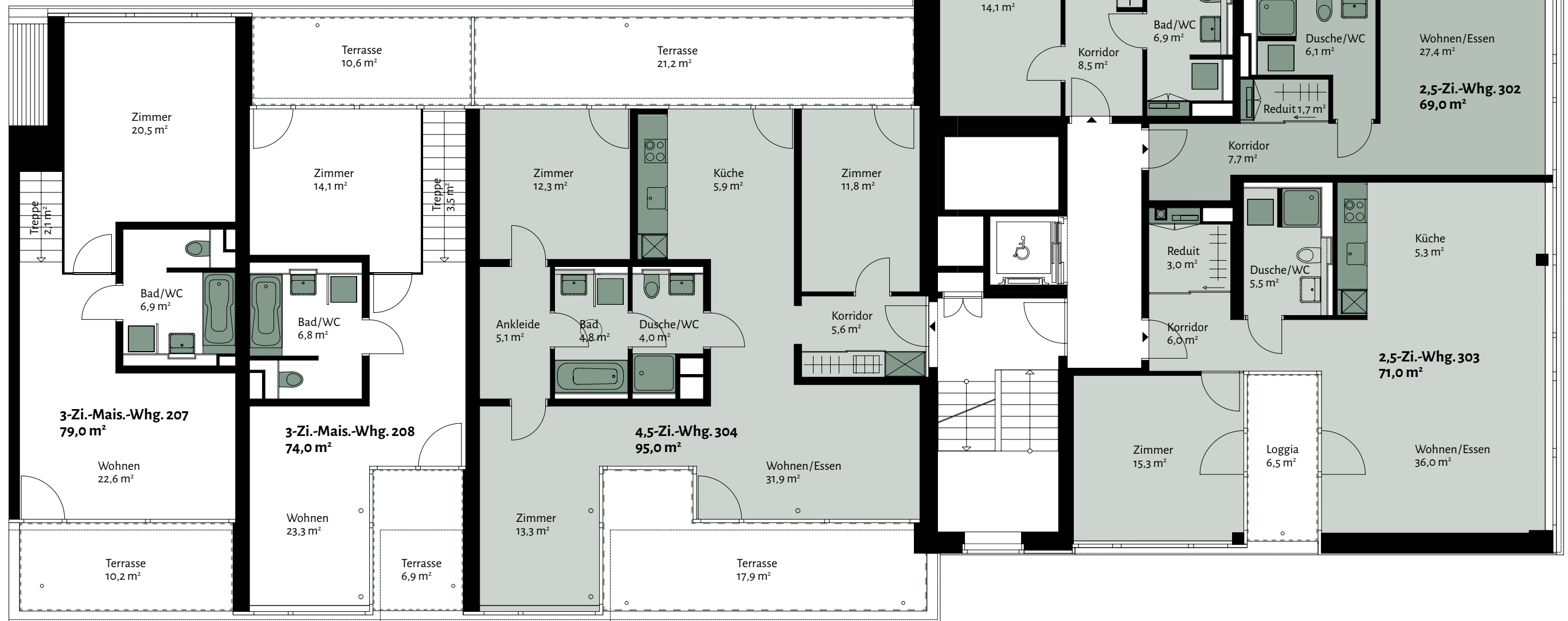
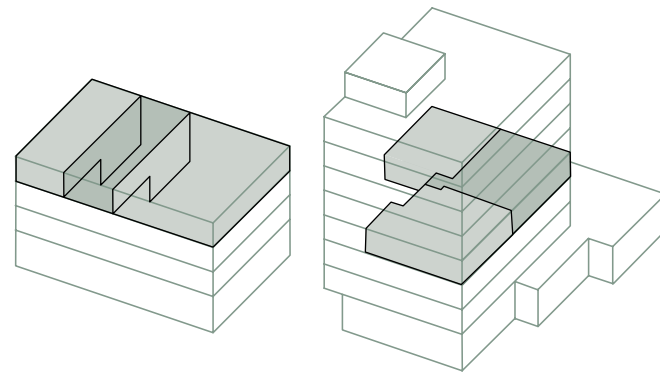

4½-Zimmer-Wohnung 304	3.OG
Nettowohnfläche	95,0 m ²
Terrassen	21,2 m ² /17,9 m ²

2½-Zimmer-Wohnung 301	3.OG
Nettowohnfläche	62,0 m ²

2½-Zimmer-Wohnung 303	3.OG
Nettowohnfläche	71,0 m ²
Loggia	6,5 m ²

2½-Zimmer-Wohnung 302	3.OG
Nettowohnfläche	69,0 m ²
Loggia	6,5 m ²



4.-7. OBERGESCHOSS HOCHHAUS

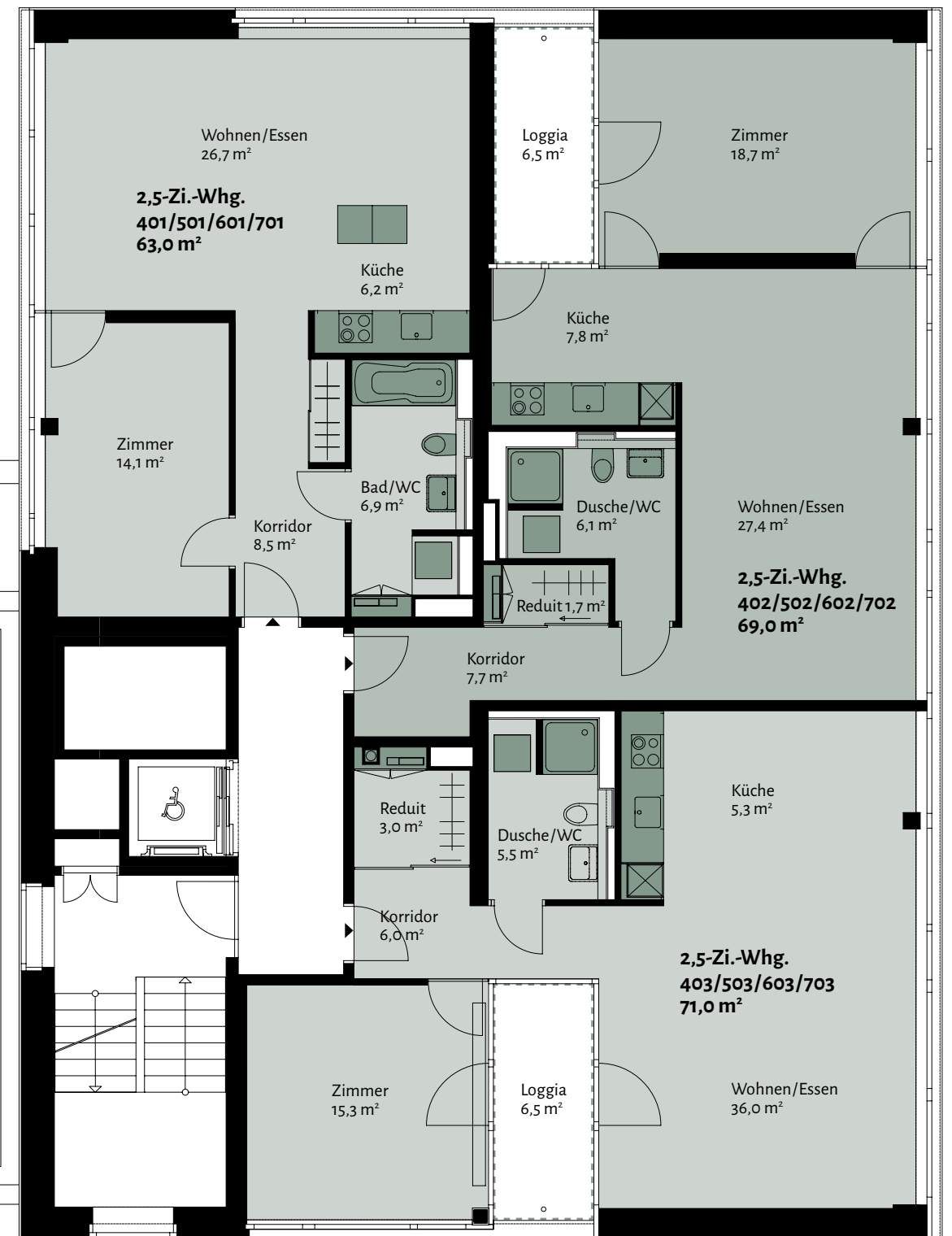
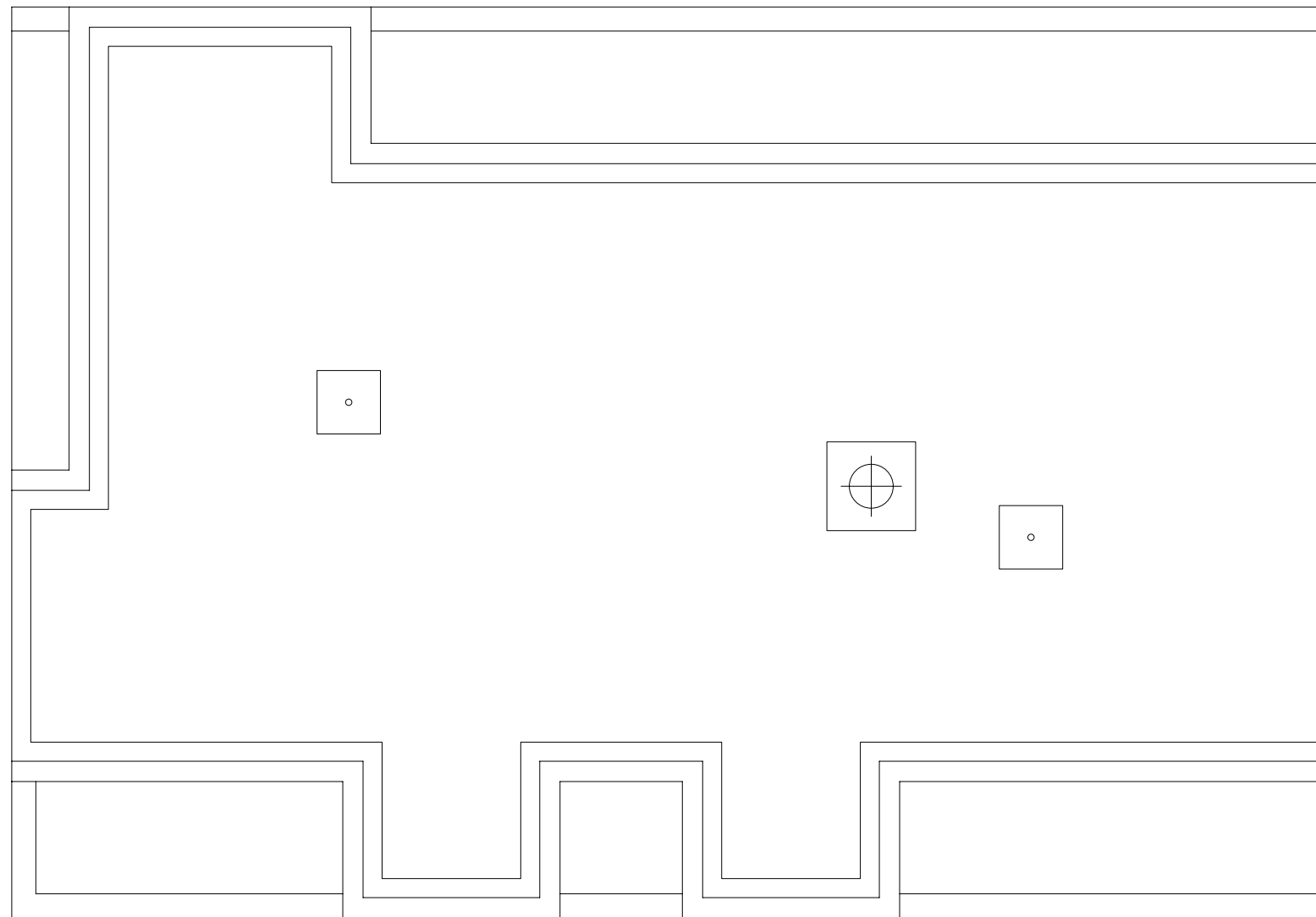
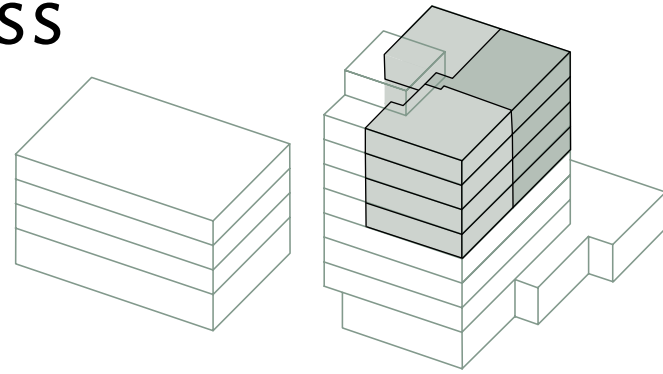

2½-Zimmer-Wohnung 401/501/601/701 4.-7. OG
 Nettowohnfläche 63,0 m²

2½-Zimmer-Wohnung 403/503/603/703 4.-7. OG
 Nettowohnfläche 71,0 m²
 Loggia 6,5 m²

2½-Zimmer-Wohnung 402/502/602/702 4.-7. OG
 Nettowohnfläche 69,0 m²
 Loggia 6,5 m²



**KONTAKT & VERMIETUNG
WOHNUNGEN:**

ARLAS IMMOBILIEN GmbH

Arlas Immobilien GmbH
Tachlisbrunnenstrasse 39
8400 Winterthur

Gerhard Lang
T 052 534 18 17
info@arlas-immobilien.ch

**KONTAKT UND VERMIETUNG
GEWERBE:**

Halter AG
Hardturmstrasse 134
8005 Zürich

Ingila Baumann
T 044 434 24 25
ingila.baumann@halter.ch

BAUHERRSCHAFT:

MPK

MIGROS-PENSIONS-KASSE

Migros-Pensionskasse
Immobilien

